

# GEV-TB External Frame Grabber

Optimizes CPU Usage, Reduces System Costs and Simplifies Connectivity for High-Bandwidth GigE Vision Imaging Applications

## Overview

Pleora's **iPORT GEV-TB External Frame Grabber** solves critical performance and system cost issues to enable the seamless deployment of high-bandwidth GigE Vision imaging applications. Combining the advantages of GigE Vision, PCIe, and Thunderbolt, the external frame grabber optimizes processing performance and system latency, and enables networked multi-camera applications, while empowering the use of laptops, workstations/desktop PCs, embedded platforms, and single-board computers for analysis and display.

The iPORT GEV-TB External Frame Grabber converts GigE Vision cameras into PCIe cameras and transmits high bandwidth (up to 22.5 Gbps) imaging and video data with low, predictable latency over a standard Cat5e or Cat6A Ethernet cable directly to a Thunderbolt/USB 4 or Thunderbolt 3/4 (USB-C) port.

The external frame grabber's built-in DMA (Direct Memory Access) engine acquires and copies full image data into the memory of the host PC with integrated packet resend management, freeing valuable processing resources for application tasks while ensuring low latency, low jitter, and high reliability performance.

In comparison, competing approaches require specialized drivers on the host PC to manage packet reception, image assembly, and data copying to memory—all while handling packet resends, which burden both processing and other system resources, tending to limit the performance of high-speed GigE Vision applications.

At the host processor, video is transmitted directly to the existing Thunderbolt (USB-C) port to deliver unparalleled computer platform flexibility and portability. Designers can reduce system size, cost, power consumption, and integration complexity by eliminating the need for a desktop computer with an available PCIe card slot for a standard network interface card (NIC), however a PC with a Thunderbolt (USB-C) connection can still be used if desired.

With the iPORT GEV-TB designers can leverage the cabling and multicasting advantages of GigE Vision for complex higher-speed applications while taking full advantage of the capabilities of lower cost, smaller form factor CPU platforms for processing, analysis, display, and recording.

The external frame grabber is supported by Pleora's feature-rich eBUS™ SDK application tool kit. With this software suite, designers can rapidly prototype and deploy production-ready software to support video transmission over GigE, 10 GigE, and USB 3.0 using the same application programming interface (API). The iPORT GEV-TB External Frame Grabber family includes a range of solutions to meet specific system requirements, including products integrating IEEE 1588 and Power Over Ethernet (PoE / PoE+) capabilities.

## GEV-TB External Frame Grabber

### Features

- Offload GigE Vision image reception from GigE Vision cameras over USB 4 / Thunderbolt with low, predictable latency and minimal CPU consumption
- Plugs into a wide range of computing platforms, including laptops and embedded and single-board computers, without needing a PCIe frame grabber card
- Available as off-the-shelf mountable enclosure and OEM board set to reduce integration complexity
- Line scan and area scan modes
- 4GB frame buffer to accommodate multi-mega pixel sensor sizes and provide hardware enabled packet resend support to ensure all image data is available for your processing needs
- High bandwidth up to 22.5 Gb/s
- Receives video from one, two or four GigE Vision cameras simultaneously with low, predictable latency over a standard Cat5e or Cat6A Ethernet cable
- GenICam compatible
- Power over Ethernet (PoE)
- IEEE 1588 synchronization support
- Full access to connected GigE Vision devices GenICam XML files for full camera control

### Concept variants

- 1x 10GigE input, 2x 10GigE input
- Basic features (no IEEE 1588 or PoE) for cost-sensitive applications

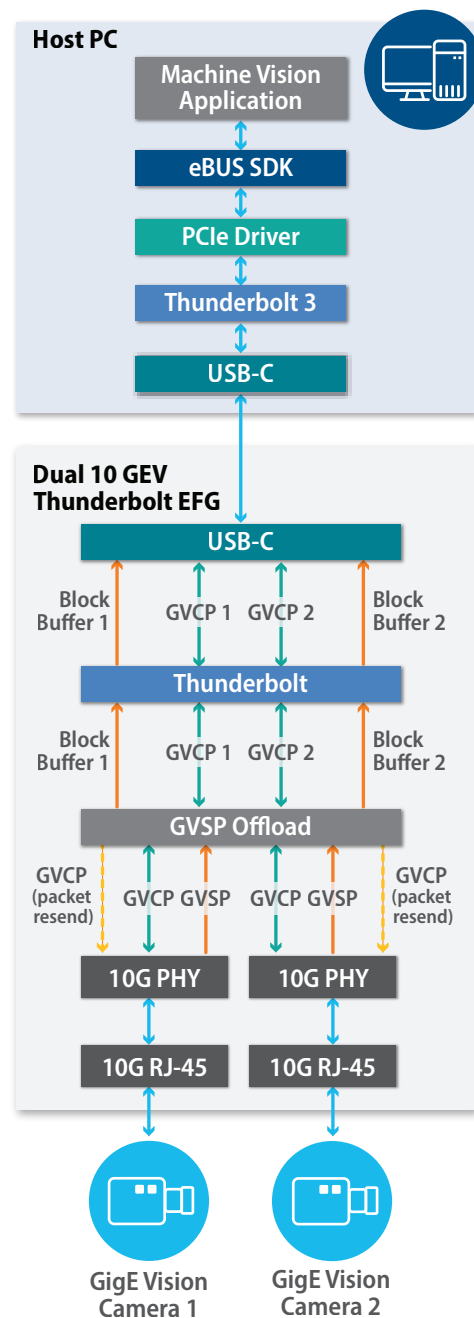

## GEV-TB External Frame Grabber

### VIDEO CONNECTIVITY SOLUTIONS

<b>External Frame Grabber</b>	<ul style="list-style-type: none"> <li>Highly reliable, up to 22.5 Gb/s bandwidth with low, end-to-end latency</li> <li>Surface-mountable enclosure</li> </ul>
<b>GigE Vision</b>	<ul style="list-style-type: none"> <li>GigE Vision 2.2 Compliant</li> <li>GigE Vision 2.1, 2.0, 1.2, 1.1 and 1.0 compatible</li> <li>Speeds up to 10Gbps</li> </ul>
<b>GenICam</b>	<ul style="list-style-type: none"> <li>Fully compatible firmware load</li> <li>Comprehensive data reception diagnostics and image statistics</li> </ul>

### VIDEO FORMATS

<b>Scan Modes</b>	Area Scan and Line Scan
<b>Tap Support</b>	Up to 10 taps
<b>Tap Geometries (GenICam SFNC)</b>	1X_1Y, 1X2_1Y, 1X, 1X2, 1X4_1Y, 1X4, 2X2E, 1X8_1Y, 1X8, 1X10_1Y, 1X10,
<b>Image Width</b>	Up to 32,760 pixels
<b>Image Height</b>	Up to 32,767 pixels
<b>Payload Types</b>	<ul style="list-style-type: none"> <li>Image with Extended Chunk Mode</li> <li>Multi-Part*</li> <li>GenDC*</li> </ul>
<b>De-compression</b>	De-compress incoming data from Pleora's RapidPIX lossless compression enabled hardware*
<b>Pixel Formats</b>	Mono, Bayer, RGB, BGR, YCbCr, YUV
<b>Pixel Depth</b>	8, 10, 12, 14, 16, 24, 30, 32 and 36 bits

### FEATURES

<b>Data Reliability</b>	Supports and manages packet resends in hardware
<b>Frame Buffer</b>	4 GB
<b>USB4-Based</b>	Connection to low-cost, easy-to-use equipment
<b>Camera Discovery</b>	<ul style="list-style-type: none"> <li>Automatic discovery and connection for GigE Vision devices</li> <li>Simple IP Configuration interface to persist IP configuration</li> <li>Manual IP configuration possible via eBUS SDK</li> </ul>
<b>Camera Control</b>	Camera GenICam XML's files passed through to host PC software for full control of any connected GigE Vision camera
<b>IEEE 1588 and ACTION_CMD Support**</b>	Built-in support for IEEE 1588 timestamp synchronization and triggering over Ethernet
<b>Pre-processing</b>	<ul style="list-style-type: none"> <li>Bayer Decode</li> <li>Unpacking of packed pixel formats</li> <li>Bayer pattern to RGB decode</li> </ul>

### CONNECTORS

<b>Video Input</b>	<ul style="list-style-type: none"> <li>Single GigE Vision (10Gbps / 5Gbps / 2.5Gbps / 1 Gbps) (1x RJ-45 connection, with locking screws***)</li> <li>Dual GigE Vision (10Gbps / 5Gbps / 2.5Gbps / 1 Gbps) (2x RJ-45 connections, with locking screws***)</li> </ul>
<b>Video Output</b>	USB-C receptacle with locking screw connectors***
<b>Power In</b>	Power Connector (TBD)
<b>Power Out</b>	PoE / PoE + on RJ-45 connectors**

### CHARACTERISTICS

<b>Size (L x W x H)</b>	TBD
<b>Operating Temperature</b>	<ul style="list-style-type: none"> <li>Enclosed: 0°C to 45°C</li> <li>OEM board sets: TBD†</li> </ul>
<b>External Power Supply</b>	12V
<b>Power Consumption</b>	TBD

### PRODUCTS

<b>Single GigE Vision Connection</b>	<ul style="list-style-type: none"> <li>1x GigE Vision (10Gbps / 5Gbps / 2.5Gbps / 1Gbps) to Thunderbolt 3 or Thunderbolt 4 (/USB4) tunneled over PCIe.</li> <li>1x GigE Vision (10Gbps / 5Gbps / 2.5Gbps / 1Gbps) to Thunderbolt 3 or Thunderbolt 4 (/USB4) tunneled over PCIe, with PoE, built-in IEEE 1588 capabilities</li> </ul>
<b>Dual GigE Vision Connections</b>	<ul style="list-style-type: none"> <li>2x GigE Vision (10Gbps / 5Gbps / 2.5Gbps / 1Gbps) to Thunderbolt 3 or Thunderbolt 4 (/USB4) tunneled over PCIe.</li> <li>2x GigE Vision (10Gbps / 5Gbps / 2.5Gbps / 1Gbps) to Thunderbolt 3 or Thunderbolt 4 (/USB4) tunneled over PCIe, with PoE, built-in IEEE 1588 capabilities</li> </ul>

\* Future product addition, contact Pleora sales for additional information.

\*\* Product variant dependent.

\*\*\* Locking connectors are only available for enclosed variants.

† Case and junction temperature limits vary by IC device. Please refer to User Guide for specific IC operating temperature specifications and thermal management information.